

DAWN HOLD DOWN ACTION TOGGLE CLAMPS VERTICAL HANDLE

All vertical handle models have red ergonomic grips except the T-handle models. Many options are available in most model sizes including straight or flanged bases, solid or U-bars, extra length and stainless steel. Refer to Model Identification Code. Bolt retainers are furnished with solid bar models, flanged washers with U-bar models. Adjustment spindles are provided with models 201 and 202. They can be purchased separately for models 207 (part no. 207 203M), 210 (part no. 240 208M), 247 (part no. 247 208M), 267 (part no. 250 203M),

MODEL IDENTIFICATION CODE

- B** Straight Base - No Flange
- L** Extra Long Bars
- S** Solid Holding Bar
- SS** Stainless Steel
- T** 'T' shaped handle
- U** 'U' shaped Holding Bar

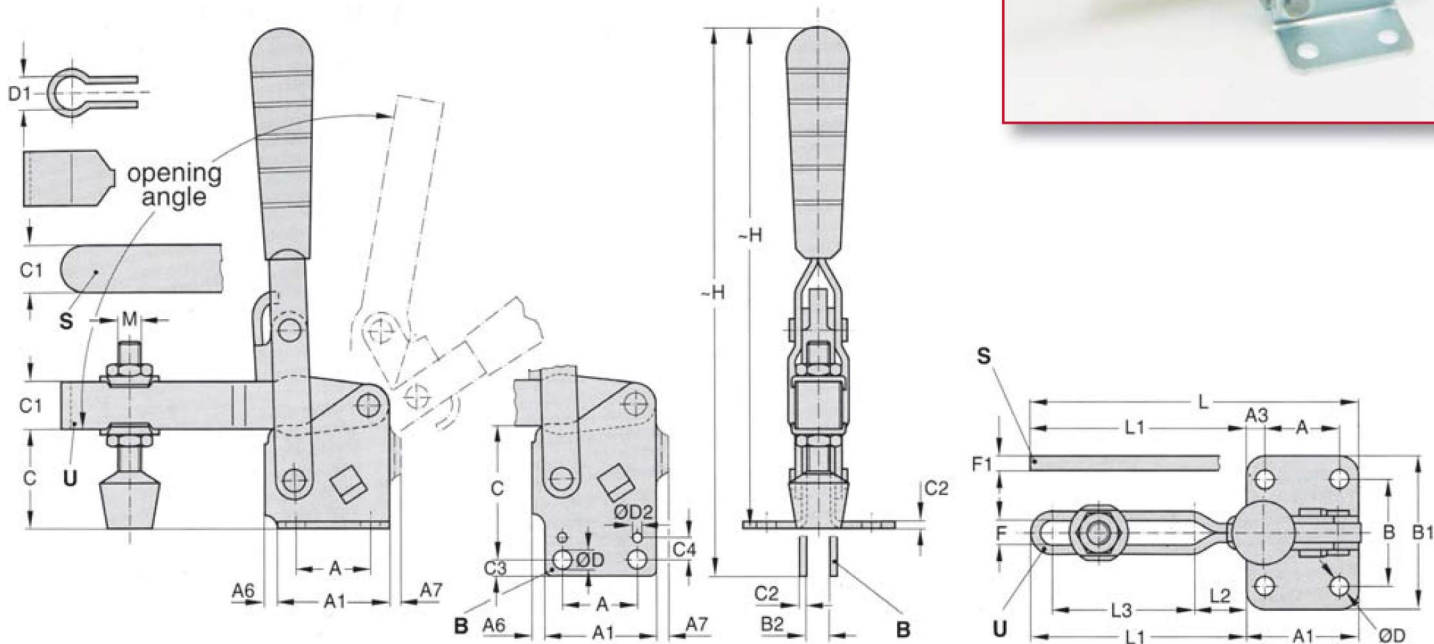

MODEL NO.	A	A1	A3	A7	B	B1	B2	C	C1	C2	C3	ØD	ØD1	F	F1	~H	L	L1	L2	L3	M	HOLDING CAPACITY kgs	WEIGHT kgs
201	16	26	5	-	24	34	-	16	8	2	-	4.4	-	5.5	-	77	51	26	-	18	M4	45	0.1
201-SS	16	26	5	-	24	34	-	16	8	2	-	4.4	-	5.5	-	77	51	26	-	18	M4	56	0.1
201-B	16	26	5	-	-	-	4	22	8	2	5	4.4	-	5.5	-	83	51	26	-	18	M4	45	0.1
202-U	12.5	25.5	6.5	-	27	39	-	23	9.5	3.2	-	5.3	-	6.5	-	98	75	43	13	24	M6	110	0.2
202-UB	12.5	25.5	6.5	-	-	-	6	28	9.5	3.2	6	5.3	-	6.5	-	107	75	43	13	24	M6	110	0.2
202-USS	12.5	25.5	6.5	-	27	39	-	23	9.5	3.2	-	5.3	-	6.5	-	98	75	43	13	24	M6	113	0.2
207-U	19	35	8	8	32	45	-	31.9	16	3.2	-	6.5	-	8.3	-	143	96	55.5	15.5	33	M8	170	0.4
207-UL	19	35	8	8	32	45	-	31.9	16	3.2	-	6.5	-	8.3	-	143	132	95.3	15.5	76.2	M8	170	0.5
207-UB	19	35	8	8	-	-	6	39.8	16	3.2	6.5	6.5	-	8.3	-	153	96	55.5	15.5	33	M8	170	0.4
207-ULB	19	35	8	8	-	-	6	39.8	16	3.2	6.5	6.5	-	8.3	-	153	132	95.3	15.5	76.2	M8	170	0.5
207-USS	19	35	8	8	32	45	-	31.9	16	3.2	-	6.5	-	8.3	-	143	96	55.5	15.5	33	M8	170	0.4
207-S	19	35	8	8	32	45	-	31.9	16	3.2	-	6.5	8.3	-	6	143	130.5	90	-	-	-	200	0.4
207-SB	19	35	8	8	-	-	6	39.8	16	3.2	6.5	6.5	8.3	-	6	153	130.5	90	-	-	-	200	0.4
207-L	19	35	8	8	32	45	-	31.9	16	3.2	-	6.5	-	8.3	-	143	125	87.3	15.5	76.2	-	170	0.5
207-LB	19	35	8	8	-	-	6	39.8	16	3.2	6.5	6.5	8.3	-	6	153	125	87.3	-	-	-	200	0.5
210-U	32	48	8	3	45	65	-	42	20	3.2	-	8.3	-	10.2	-	195	141	92.8	22	61	M10	280	0.6
210-UB	32	48	8	3	-	-	8.2	55.5	20	3.2	10	8.3	-	10.2	-	218	141	92.8	22	61	M10	280	0.6
210-USS	32	48	8	3	45	65	-	42	20	3.2	-	8.3	-	10.2	-	195	141	92.8	22	61	M10	340	0.6
210-S	32	48	8	3	45	65	-	4.2	20	3.2	-	8.3	13	-	8	195	139	91	-	-	-	340	0.6
210-SB	32	48	8	3	-	-	8.2	55.5	20	3.2	10	8.3	13	-	8	218	139	91	-	-	-	340	0.6
247-U	32	51	9.5	3	45	64	-	51	22	8	-	8.5	-	13.5	-	225	178	124	34.5	80	M12	360	1.1
247-UB	32	51	9.5	3	-	-	9.5	57	22	5	9.5	8.5	-	13.5	-	240	178	124	34.5	80	M12	360	1.1
247-S	32	51	9.5	3	45	64	-	51	22	8	-	8.5	14	-	9.5	225	178	124	-	-	-	450	1.1
247-SB	32	51	9.5	3	-	-	9.5	57	22	5	9.5	8.5	14	-	9.5	240	178	124	-	-	-	450	1.1
267-U	51	77	13	3	70	95	-	82	32	8	-	12.2	-	16.6	-	310	230	148	37	98	M16	540	2.2
267-S	51	77	13	3	70	95	-	82	32	8	-	12.2	16.3	-	9.5	343	230	148	-	-	-	540	2.2
267-UB	51	77	13	3	-	-	9.5	102	32	5	13	12.2	-	16.6	-	310	230	148	37	98	M16	540	2.2
267-SB	51	77	13	3	-	-	9.5	102	32	5	13	12.2	16.3	-	9.5	343	230	148	-	-	-	540	2.2

All dimensions in mm